

# Mold Skirts

## Soft Drop Application

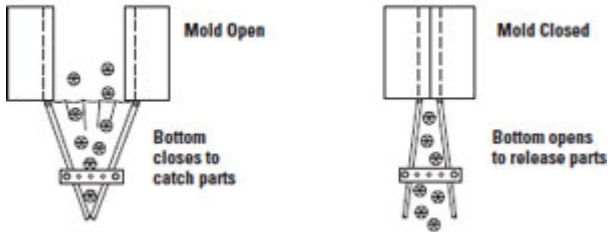

## Part/Runner Separation

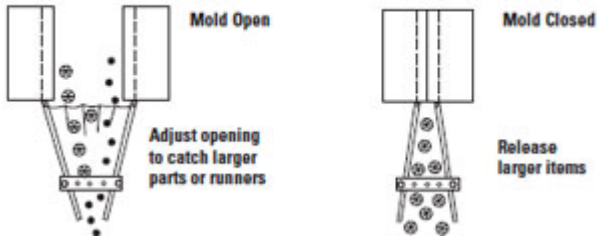

Protects delicate molded parts

Delayed drop guideskirts provide a soft, delayed, controlled drop of molded parts - prevents damage and increases output of delicate molded parts.

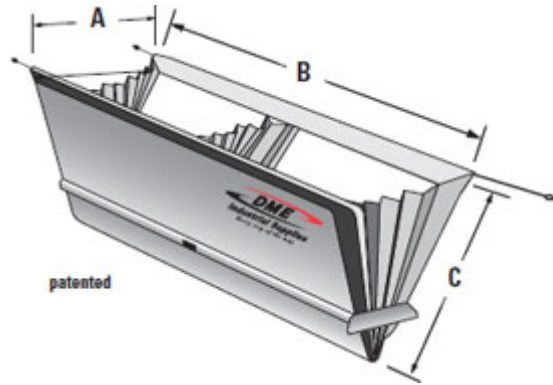

**Call For Pricing!**

Please provide all required dimensional details for a rapid quotation for your machine.

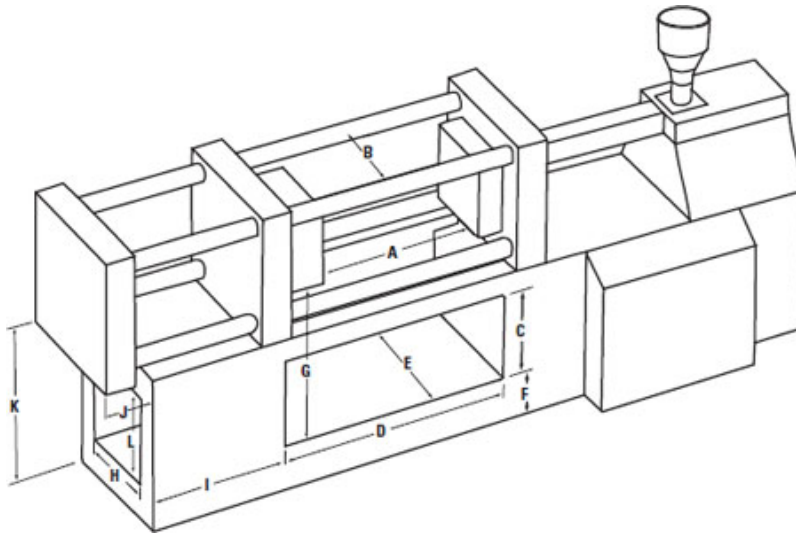

A: Mold open .....	_____	F: Floor to opening .....	_____
E: Width of opening .....	_____	I: End to opening .....	_____
C: Height of opening .....	_____	L: Height of end opening .....	_____
D: Length of opening .....	_____	H: Width of opening .....	_____

Company: \_\_\_\_\_  
 Contact: \_\_\_\_\_  
 Address: \_\_\_\_\_  
 City: \_\_\_\_\_ State: \_\_\_\_\_  
 Zip: \_\_\_\_\_  
 Country: \_\_\_\_\_

Account Number: \_\_\_\_\_  
 PO #: \_\_\_\_\_ Job #: \_\_\_\_\_  
 Phone: \_\_\_\_\_  
 Fax #: \_\_\_\_\_  
 E-mail: \_\_\_\_\_

**SUBMIT**