



Metal Filter

For all makes and models of injection molding machines

Please email completed form to: dmeus-csspecials@dme.net

Ordering information for Screen Pack Filters & Adapters.

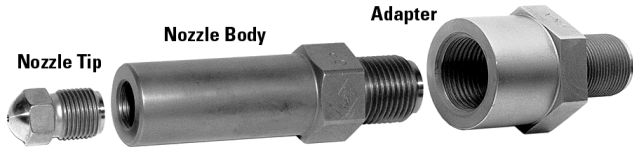

New design nozzle filter for tramp metal provides all the benefits of huge filtering capacity. Available from stock shipment to get you running without delay. Uses standard Adapters with thread to suit your machine; standard "VR" nozzles, with 1 3/4" thread and regular replacement tips.



TMF40 Filter Disk

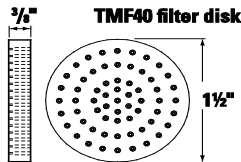
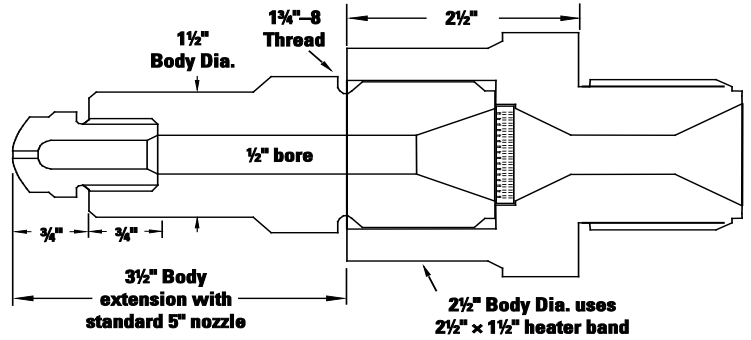

63 holes
Major diameter .093"
Minor diameter .035"

Item	Part Number
Adapter	TMPA
Filter	TMF40
5" Nozzle (including Tip)	V 5AT

General purpose

If your nozzle thread specification is not shown on the following pages, please complete the dimensional data shown above and send to DME.

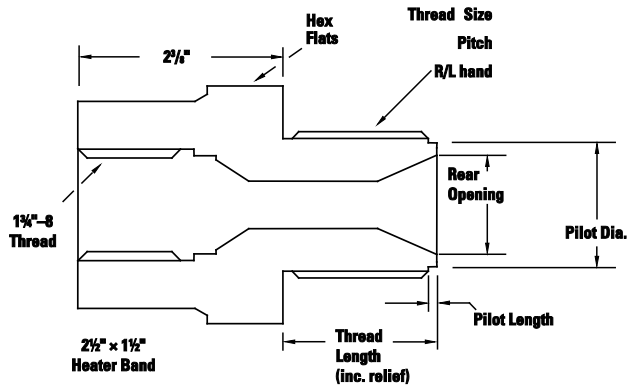

Send the information requested in the six boxes above and nozzle tip details below via fax to 888-808-4363 or via email to DME@dme.net.

(a) Radius (flat, 1/2", 3/4", etc.)

(b) Orifice (from table)

(c) Internal Design
(general purpose, nylon reverse taper or ABS full taper)

Machine Make _____ Model _____ Year _____

Company: _____
 Account Number: _____
 Address: _____
 City: _____
 State/Zip: _____

Contact Name: _____
 Phone: _____
 Fax: _____
 E-mail: _____