

ME-0741-PS-531-D      09-09      ETH9997  
**INSTALLATION DATA**  
**For: 250 & 375 SERIES POINT GATE NEEDLE**  
 Please read carefully before installing components.

NOTE: Dimensions are shown in Inches.

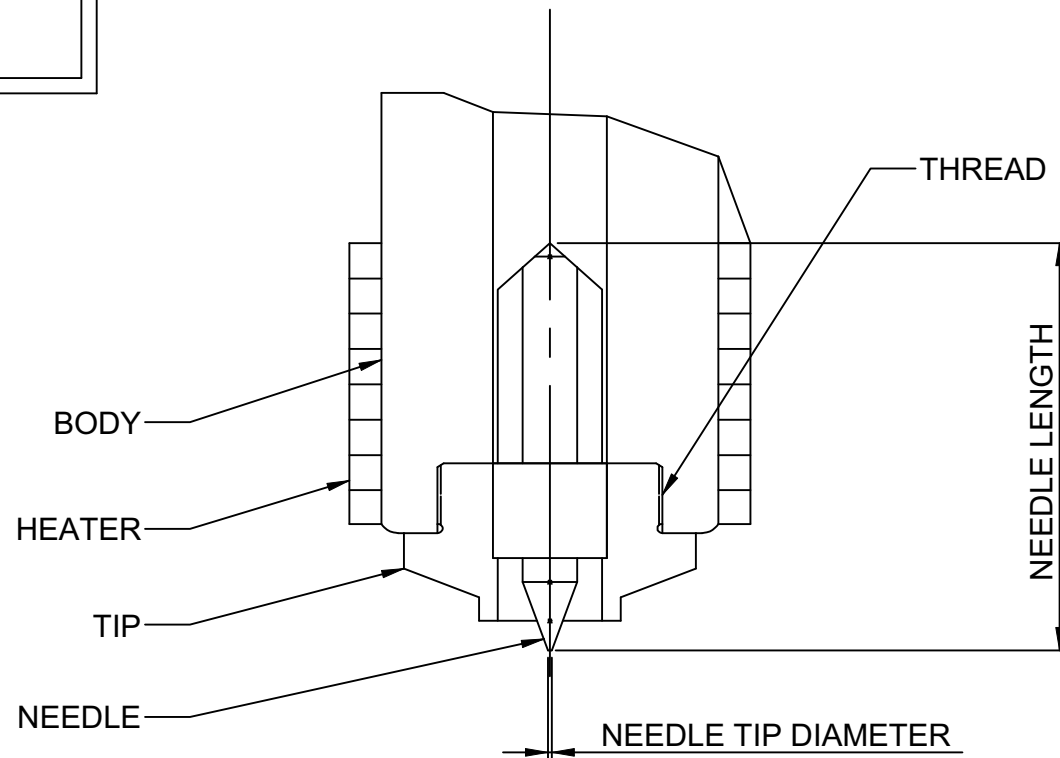

POINT GATE NEEDLE CATALOG NUMBER	NEEDLE TIP DIAMETER	NEEDLE LENGTH	THREAD	USED WITH TIP SUB-ASSEMBLY CATALOG NUMBER
*EHN0015	0.010	1.680	1/2-24	EHT0005 (250 SERIES)
EHN0300				EHT0302 (250 SERIES)
*EHN0016			5/8-20	EHT0039 (375 SERIES)
EHN0301				EHT0303 (375 SERIES)

\* EHN0015 and EHN0016 needles NOT recommended for abrasive materials.

ME-0741-PS-531-D

09-09 ETH9997

## INSTALLATION DATA

For: 250 & 375 SERIES POINT GATE NEEDLE

Please read carefully before installing components.



## RECOMMENDATIONS AND GUIDELINES

1. Nozzle (multiple-applications) body must be cleaned of any material in the seal off area and threaded areas before reassembling.
2. Careful attention should be taken to the needle as damage could occur if needle is dropped or strikes a rigid material. Treat needle like a glass or ceramic material.
3. Apply an anti-sieze compound on the tip threads.
4. Tip must be torqued into the nozzle body using  $30 \pm 5$  ft-lbs. When reassembling. For protection of the needle point, a six point deep well socket is recommended.
5. Careful attention should be taken to the heater/thermocouple leads as damage could occur when working on nozzle or bushing assembly.
6. Seal ring for nozzle body must be replaced each time nozzle body and/ or manifold are removed to ensure seal off.
7. Wait a minimum of 5 minutes after set point has been achieved for sufficient heat to transfer into the needle before molding.

## IMPORTANT SAFETY INFORMATION

A hot-runner system includes electrical elements and may contain molten plastic at elevated temperature and pressure. To avoid injury, exercise caution by reading these instructions before servicing or operating the system.

These instructions must be passed on to the end user where they should be read before using this product. Failure to do so can result in serious injury or death.



Failure to comply will result in serious injury or death:

### ELECTRICAL HAZARDS

Improper voltages or grounding can result in electrical shock. Use only with proper voltage and a proper earth ground.

To avoid electrical shock, do not operate product when wet.

Do not operate this equipment with covers or panels removed.

To avoid electrical shock, turn off main power disconnect and lockout / tag out before servicing this device. Do not connect temperature sensors to electrical power. It will damage the product and it can cause fire, severe injuries or even death.

If green ground wire present wire must be connected to the ground.

Do not rebend rigid leads. Rebending leads might result in damage to circuit.

Product might absorb moisture when cool. Use low Voltage or power to drive out residual moisture before applying full power. Failure to do so may cause damage to this product.



Failure to comply can result in serious injury or death:

### STORED ENERGY AND HIGH TEMPERATURE HAZARDS

This product maintains molten plastic at high pressure. Use caution when operating and servicing the system.

Physical contact with molten plastic may result in severe burns. Proper protective equipment, including eye protection, must be worn. This product has heated surfaces. Use caution when operating and servicing the system to avoid severe burns. Proper protective equipment should be worn.

DME SHALL NOT BE LIABLE FOR MISUSE OR FAILURE TO FOLLOW THE ENCLOSED INSTRUCTIONS AND SPECIFICATIONS. D-M-E HERBY TO DISCLAIM ALL IMPLIED WARRANTIES, INCLUDING MERCHANTABILITY AND FITNESS FOR A PARTICULAR PURPOSE. IN NO EVENT SHALL D-M-E BE RESPONSIBLE FOR LOSS OF USE, REVENUE OR PROFIT, OR FOR INCIDENTAL OR CONSEQUENTIAL DAMAGED.

## DME COMPANY LLC

29111 STEPHENSON HIGHWAY  
MADISON HEIGHTS  
MICHIGAN 48071 USA  
US 800-656-6656  
CANADA 800-387-6600  
www.dme.net