

Codipro Swivel Eyebolts, Rings & Shackles



SEB Swivel Eye Bolt

Features:



- Swivels under the load
- Equipped with an automatic position recovery system
- Tightens with Allen Wrench
- High WLL in all directions
- Optimizes orientation in the direction of the sling
- Standard in Metric and Inch
- Adaptor, centering feature and special thread options available as special order

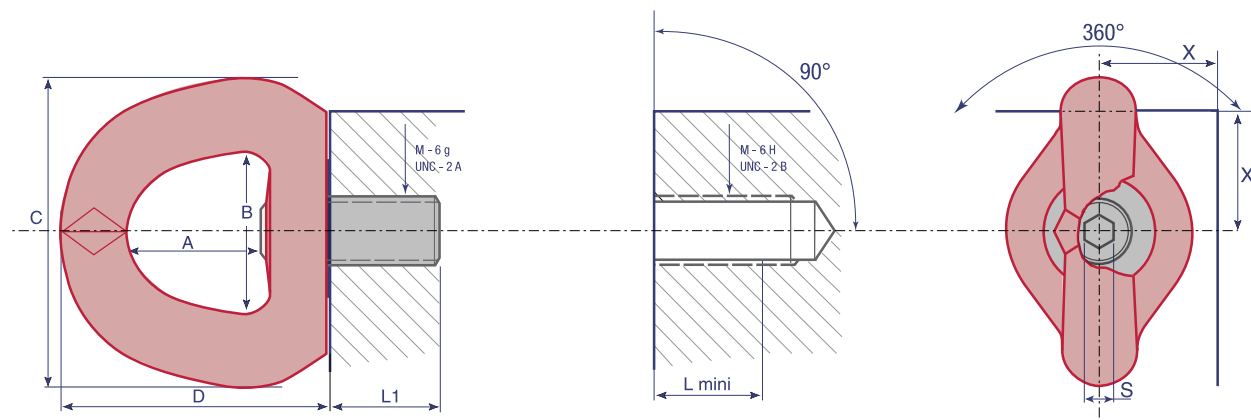

PART NUMBER	THREAD	WORK LOAD LIMIT (LBS)	STANDARD L1	N.m FOOT/LBS		S	A	B	C	D
SEBM8	M8 X 1.25	660	14	6	20	6	30	34	60	57
SEBM10	M10 X 1.5	1,320	17	10	20	6	30	34	60	57
SEBM12	M12 X 1.75	2,200	21	15	20	6	30	34	60	57
SEBM16	M16 X 2	3,520	27	50	35	8	38	45	90	78
SEBM20	M20 X 2.5	5,500	30	100	35	8	38	45	90	78
SEBM24	M24 X 3	8,800	36	160	50	14	58	70	134	115
SEBM30	M30 X 3.5	13,860	45	250	50	14	58	70	134	115
SEBM36	M36 X 4	22,000	54	320	70	14	88	94	190	166
SEBM42	M42 X 4.5	27,500	63	400	70	14	88	94	190	166
SEBM48	M48 X 5	33,000	68	600	70	19	88	94	190	166
SEB3/8	UNC 3/8-16	1,200	16	8 _{FL}	20	4	30	34	60	57
SEB1/2	UNC 1/2-13	2,200	21	12 _{FL}	20	4	30	34	60	57
SEB5/8	UNC 5/8-11	3,800	27	40 _{FL}	35	8	38	45	90	78
SEB3/4	UNC 3/4-10	5,500	30	80 _{FL}	35	8	38	45	90	78
SEB1INCH	UNC 1-8	10,000	36	125 _{FL}	50	14	58	70	134	115
SEB11/4	UNC 1 1/4-7	14,000	45	200 _{FL}	70	14	58	70	134	115
SEB11/2	UNC 1 1/2-6	20,000	62	300 _{FL}	70	14	88	94	190	166





DSR Double Swivel Rings Specially Designed for Lifting Under Load

Features:

- Swivels under the load
- Designed for loads in rotation with Axial Shackle
- Two ways of tightening; open-ended spanner or allen key
- Axial shackle position
- Standard in Metric and Inch
- Stainless steel, adaptor, centering feature and special thread options available as special order

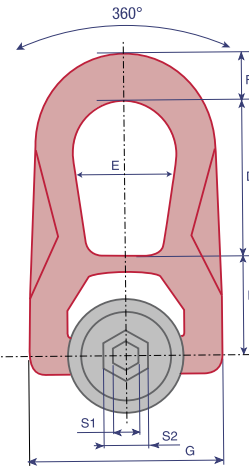
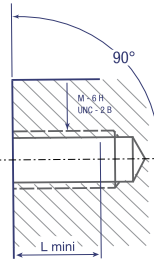
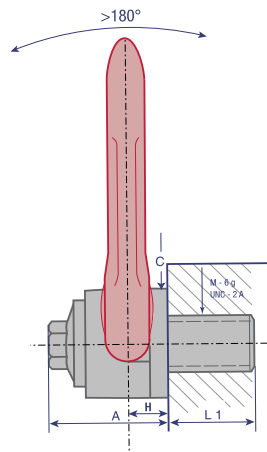

PART NUMBER	THREAD	WORK LOAD LIMIT (LBS)	STANDARD L1	N.m FOOT/LBS	S1	S2	A	B	C	D	E	F	G	H
DSRM4	M4 (x0.7)	110	15	2	3		33	30	30	38	27	14	53	9.5
DSRM5	M5 (x0.8)	165	15	3	4		33	30	30	38	27	14	53	9.5
DSRM6	M6 (x1)	220	15	4	5		33	30	30	38	27	14	53	9.5
DSRM8	M8 (x1.25)	660	14	6	8	16	33	30	30	38	27	14	53	9.5
DSRM10	M10 (x1.50)	1,320	17	10	8	16	33	30	30	38	27	14	53	9.5
DSRM12	M12 (x1.75)	2,200	21	15	8	16	33	30	30	38	27	14	53	9.5
DSRM14	M14 (x2)	2,860	23	30	8	20	33	42	45	54	38	17	76	13
DSRM16	M16 (x2.5)	3,520	27	50	8	20	45	42	45	54	38	17	76	13
DSRM18	M18 (x2.5)	4,400	27	70	8	20	45	42	45	54	38	17	76	13
DSRM20	M20 (x2.5)	5,500	30	100	8	20	45	42	45	54	38	17	76	13
DSRM22	M22 (x2.5)	6,600	33	120	14	24	45	55	60	83	55	25	117	19
DSRM24	M24 (x3)	8,800	36	160	14	24	62	55	60	83	55	25	117	19
DSRM27	M27 (x3)	11,000	40	200	14	24	62	55	60	83	55	25	117	19
DSRM30	M30 (x3.5)	13,860	45	250	14	24	62	55	60	83	55	25	117	19
DSR1/4	UNC 1/4-20	330	13	3 _{FL}	3/16		32	30	30	38	27	14	53	9.5
DSR5/16	UNC 5/16-18	650	15	7 _{FL}	5/16	5/8	33	30	30	38	27	14	53	9.5
DSR3/8	UNC 3/8-16	1,200	17	8 _{FL}	5/16	5/8	33	30	30	38	27	14	53	9.5
DSR1/2	UNC 1/2-13	2,200	21	12 _{FL}	5/16	5/8	33	30	30	38	27	14	53	9.5
DSR5/8	UNC 5/8-11	3,800	27	40 _{FL}	5/16	20	45	42	45	54	38	17	76	13
DSR3/4	UNC 3/4-10	5,500	30	80 _{FL}	5/16	20	45	42	45	54	38	17	76	13
DSR7/8	UNC 7/8-9	6,600	33	100 _{FL}	9/16	24	62	55	60	83	55	25	117	19
DSR1	UNC 1-8	10,000	36	125 _{FL}	9/16	24	62	55	60	83	55	25	114	19



Features:

- Large shackle for easy secure connection directly to crane hook
- Compact and Ergonomic; requires less clearance
- Tightens with allen wrench
- Double articulation allows perfect alignment with the sling
- Standard in Metric and Inch
- Stainless Steel, adaptor and special thread options available as special order

DSS Double Swivel Shackle Specially Designed for Lifting and Turning Under Heavy Load

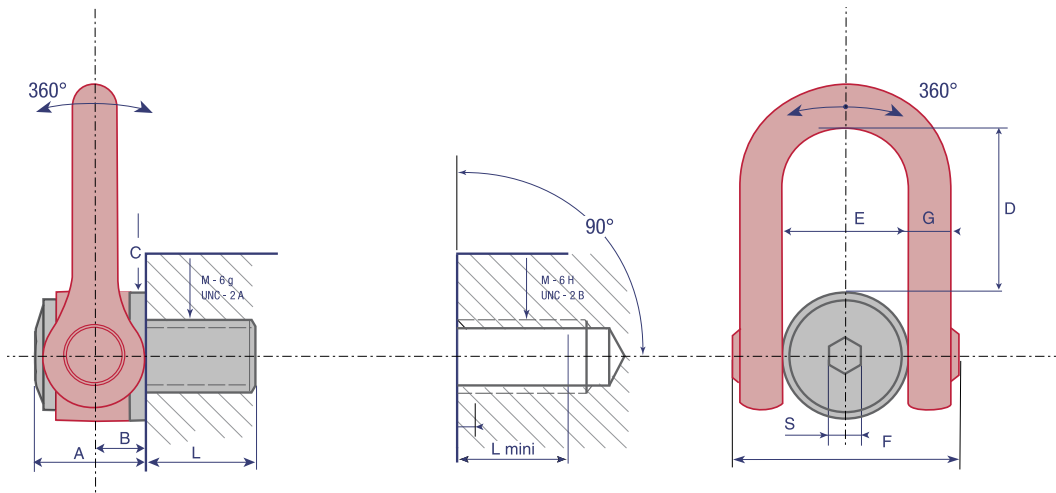

PART NUMBER	THREAD (DIA)	WORK LOAD LIMIT (LBS)	STANDARD L1	N.m FOOT/LBS	S	A	B	C	D	E	F	G
DSSM24	M24 (x3)	9,900	36	160	19	61	31	70	104	73	145	29
DSSM30	M30 (x3.5)	16,060	45	250	19	61	31	70	104	73	145	29
DSSM33	M33 (x3.5)	17,600	50	250	19	61	31	70	104	73	145	29
DSSM36	M36 (x4)	22,000	54	320	19	61	31	70	104	73	145	29
DSSM39	M39 (x4)	22,000	58	320	19	61	31	70	104	73	145	29
DSSM42	M42 (4.5)	27,500	63	400	19	61	31	70	104	73	145	29
DSSM45	M45 (x3)	33,000	63	400	19	61	31	70	104	73	145	29
DSSM48	M48(x5)	44,000	68	600	19	79	38	90	125	91	184	36
DSSM52	M52 (x3)	44,000	68	600	19	79	38	90	125	91	184	36
DSSM56	M56 (5)	55,000	78	600	19	79	38	90	125	91	184	36
DSSM64	M64 (x6)	70,620	90	600	19	79	38	95	125	91	184	36
DSSM72	M72 (x6)	55,000	90	600	19	79	38	100	125	91	184	36
DSSM80	M80 (x6)	70,620	90	600	19	79	38	100	125	91	184	36
DSSM90	M90 (x6)	70,620	90	600	19	79	38	100	125	91	184	36
DSSM100	M100 (x6)	70,620	90	600	19	79	38	110	125	91	184	36
DSS1	UNC 1"-8	10,000	36	160	19	61	31	70	104	73	145	29
DSS11/4	UNC 1" 1/4-7	14,000	45	200 _{FL}	3/4"	61	31	70	104	73	145	29
DSS13/8	UNC 1" 3/8-6	20,000	54	300 _{FL}	3/4"	61	31	70	104	73	145	29
DSS11/2	UNC 1" 1/2-6	20,000	54	300 _{FL}	3/4"	61	31	70	104	73	145	29
DSS2	UNC 2"- 4 1/2	50,000	76	450 _{FL}	3/4"	79	38	90	125	91	184	33
DSS21/2	UNC 2" 1/2-4	55,000	90	600	19	79	38	95	125	91	184	36



MEGADSS

Double Swivel Shackle

Specially Designed for Lifting and Turning Loads up to 50 Tons



Features:

- Large shackle for easy secure connection directly to crane hook
- Compact and Ergonomic; requires less clearance
- Tightens with allen wrench
- Double articulation allows perfect alignment with the sling
- Standard in Metric and Inch
- Stainless Steel, adaptor and special thread options available as special order

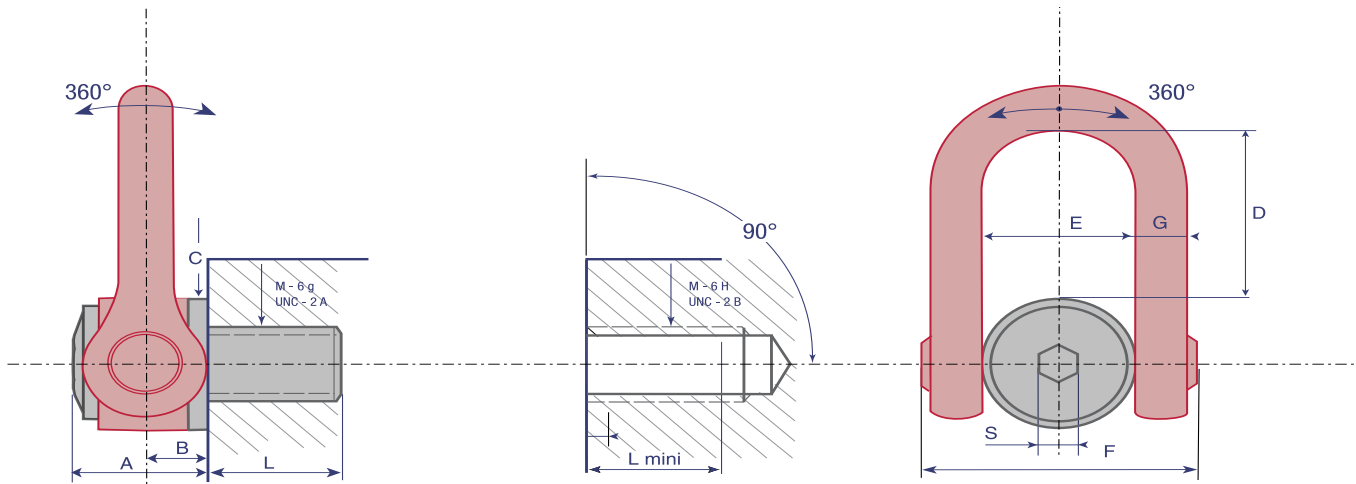

PART NUMBER	THREAD (DIA)	WORK LOAD LIMIT (LBS)	STANDARD L1	N.m FOOT/LBS	S	A	B	C	D	E	F	G
MEGADSSM64	M64 (x6)	72,600	100	600	36	127	64	140	195	143	278	59
MEGADSSM72	M72 (x6)	77,000	110	700	36	127	64	140	195	143	278	59
MEGADSSM80	M80 (x6)	88,000	120	800	36	127	64	140	195	143	278	59
MEGADSSM90	M90 (x6)	99,000	135	900	36	127	64	140	195	143	278	59
MEGADSSM100	M100 (x6)	110,000	150	1000	36	127	64	140	195	143	278	59
MEGADSS21/4	UNC 2" - 4 1/2	55,000	85	600	36	127	64	140	195	143	278	59
MEGADSS21/2	UNC 2" - 1/2-4	70,000	95	600	36	127	64	140	195	143	278	59
MEGADSS23/4	UNC 2-3/4" - 3/8-6	75000	105	700	36	127	64	140	195	143	278	59
MEGADSS3	UNC 3" - 1/2-6	80,000	115	700	36	127	64	140	195	143	278	59
MEGADSS31/4	UNC 3-1/4" - 3 1/2	90,000	125	800	36	127	64	140	195	143	278	59
MEGADSS31/2	UNC 3-1/2" - 1/2-4	95,000	135	900	36	127	64	140	195	143	278	59
MEGADSS33/4	UNC 3-3/4" - 1/2-4	100,000	145	1000	36	127	64	140	195	143	278	59
MEGADSS4	UNC 4" - 1/2-4	110,000	150	1000	36	127	64	140	195	143	278	59



CSS - Central Safety Shackle

Specially Designed for Lifting and Turning Loads up to metric 55 tons

Features:

- Large eye on the shackle for easy connections
- Compact and Ergonomic base; requires less clearance
- Easy to attach and use
- Individual engraving
- Delivered with a certificate of conformity for each shackle

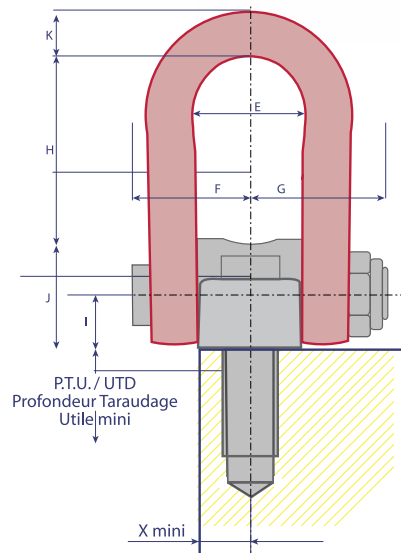
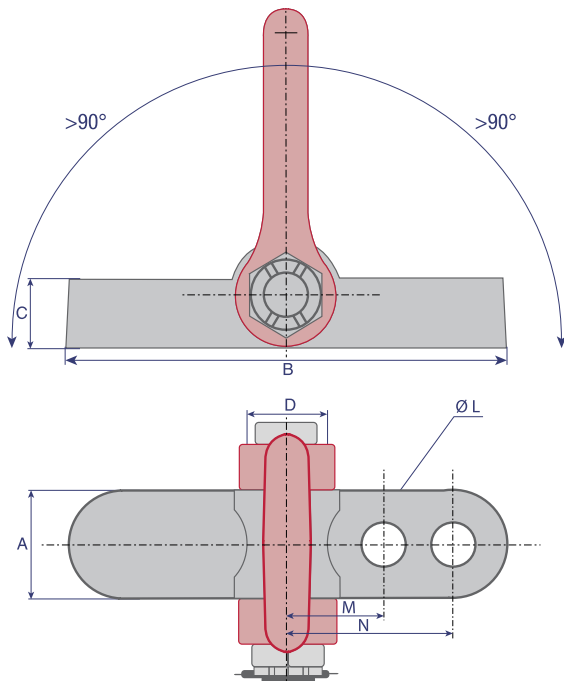

PART NUMBER	WORK LOAD LIMIT (TO)	X mini	A	B	C	D	E	F	G	H	I	J	K
CSS20T	44,000	40	80	220	50	62	90	88	98	132	38	76	41
CSS32T	70,950	40	80	330	50	62	90	88	98	132	38	76	41
CSS55T	121,000	53	105	540	85	175	184	160	170	267	85	175	79.5

Drilling and screw specifications

DIN912-12.9

PART NUMBER	DRILLING			PTU/UTD	SCREW					
	Ø L	M	N	USEFUL MIN THREAD DEPTH	QTY	THREAD	LENGTH	HEAD		N.m
								Ø	HEIGHT	
CSS20T	38	70	/	54	2	M36	100	54	36	600
CSS32T	38	70	130	54	4	M36	100	54	36	600
CSS55T	50	133	210	85	4	M48	160	72	48	600